

342578 (Coibentata - Isolee
Insulate Isoliert - Aislamiento)
342572

411002

200925

323539

352070

331225

160811

190638

190637

361069/1

390195

180642

361824

361825 (RCD)

200964

342571

352114

361094

390196

120366

324166

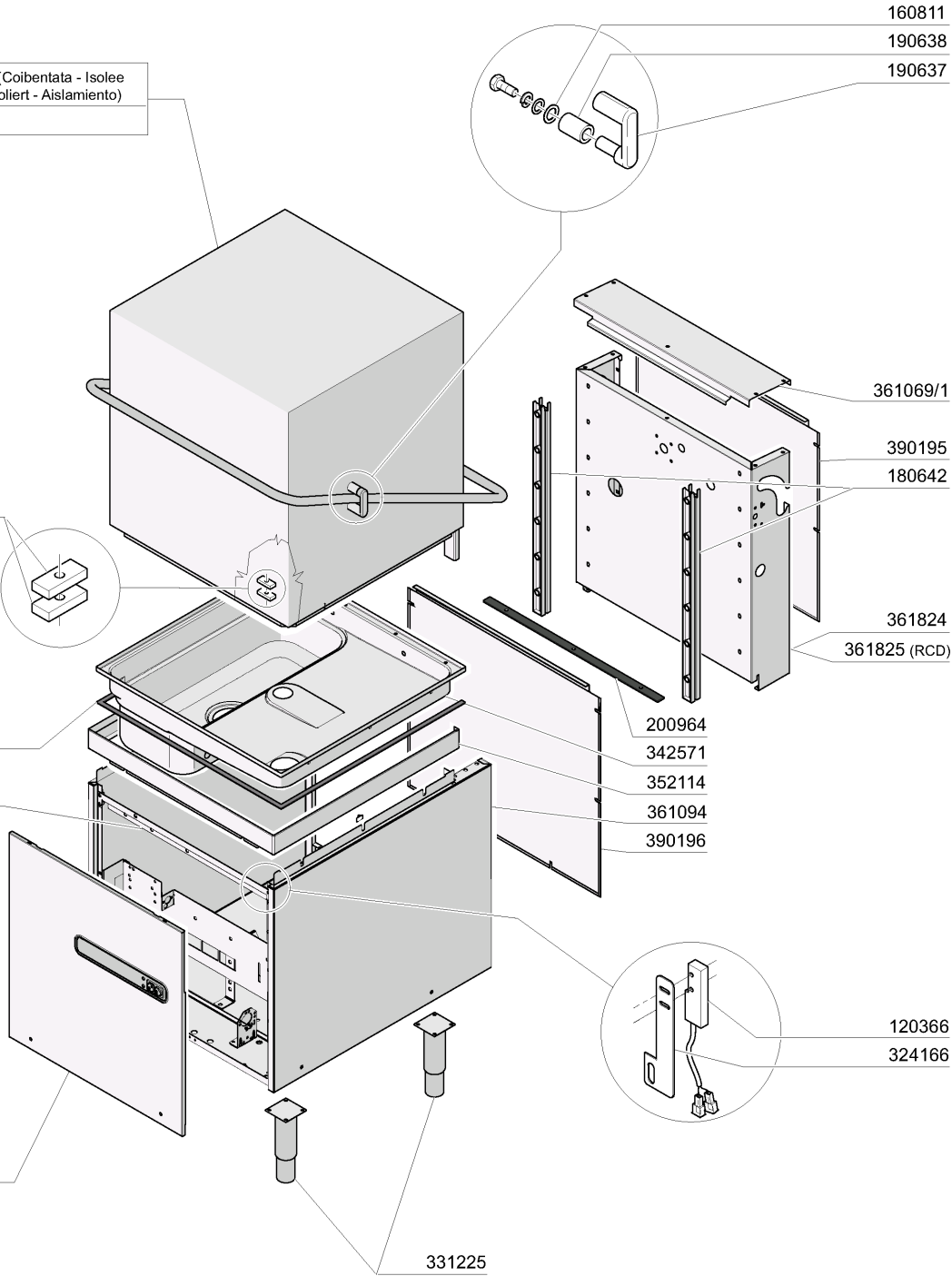

1 - Hood

CODE	DESCRIPTION
120366	MAGN.SENSOR
160811	WASHER F2 18X8.5X1 ALGOF
180642	GUIDE
190637	GUIDE FOR DOOR "C"
190638	ROLLER FOR "C" DOOR GUIDE
200925	GASKET
200964	GASKET 618X14 SP.2
323539	BRACKET
324166	BRACKET
331225	ADJUSTABLE FEET
342571	TANK
342572	HOOD
342578	ISULATED HOOD
352070	FRONT PANEL
352114	FRONT PANEL
361069/1	COVER
361094	BASEMENT
361824	BACK PANEL
361825	BACK PANEL
390195	UPPER BACK PANEL
390196	LOWER BACK PANEL
411002	PERMANENT MAGNET 24X12

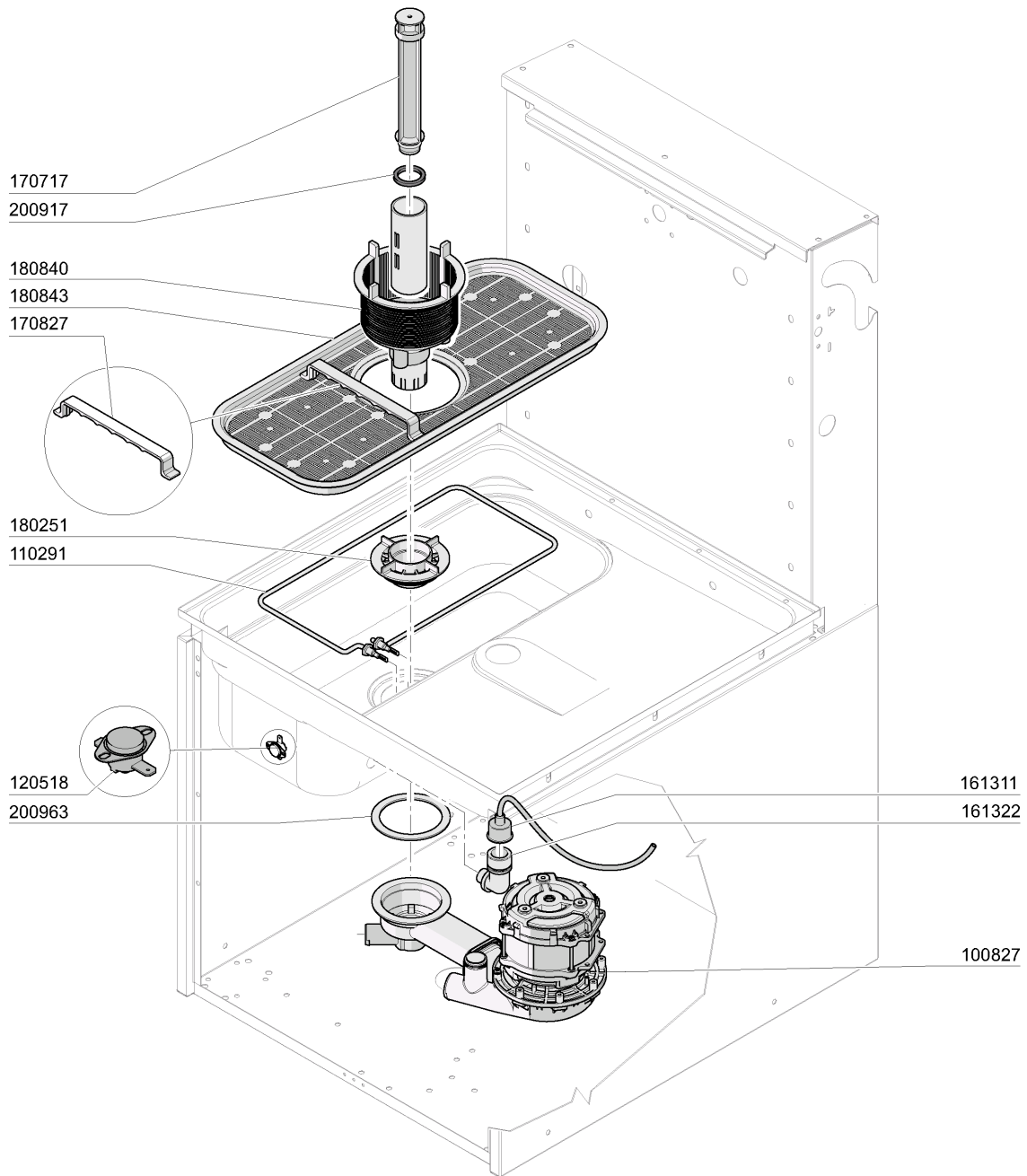

2 - Tank

CODE	DESCRIPTION
100827	WASH PUMP HP0,6 FC2006
110291	HEATER 2000W
120518	TANK THERMOSTAT FOR R50
161311	HOSE FOR AIR CHAMBER BC-BR-AC9
161322	AIR TRAP FC2006
170717	OVERFLOW PIPE FC2006
170827	FILTER HANDLE
180251	FIXING NUT FOR PUMP FC2006
180840	FCM FILTER
180843	FILTER
200917	GASKET FOR OVERFLOW PIPE BR-BC
200963	JOINT 110X88X3

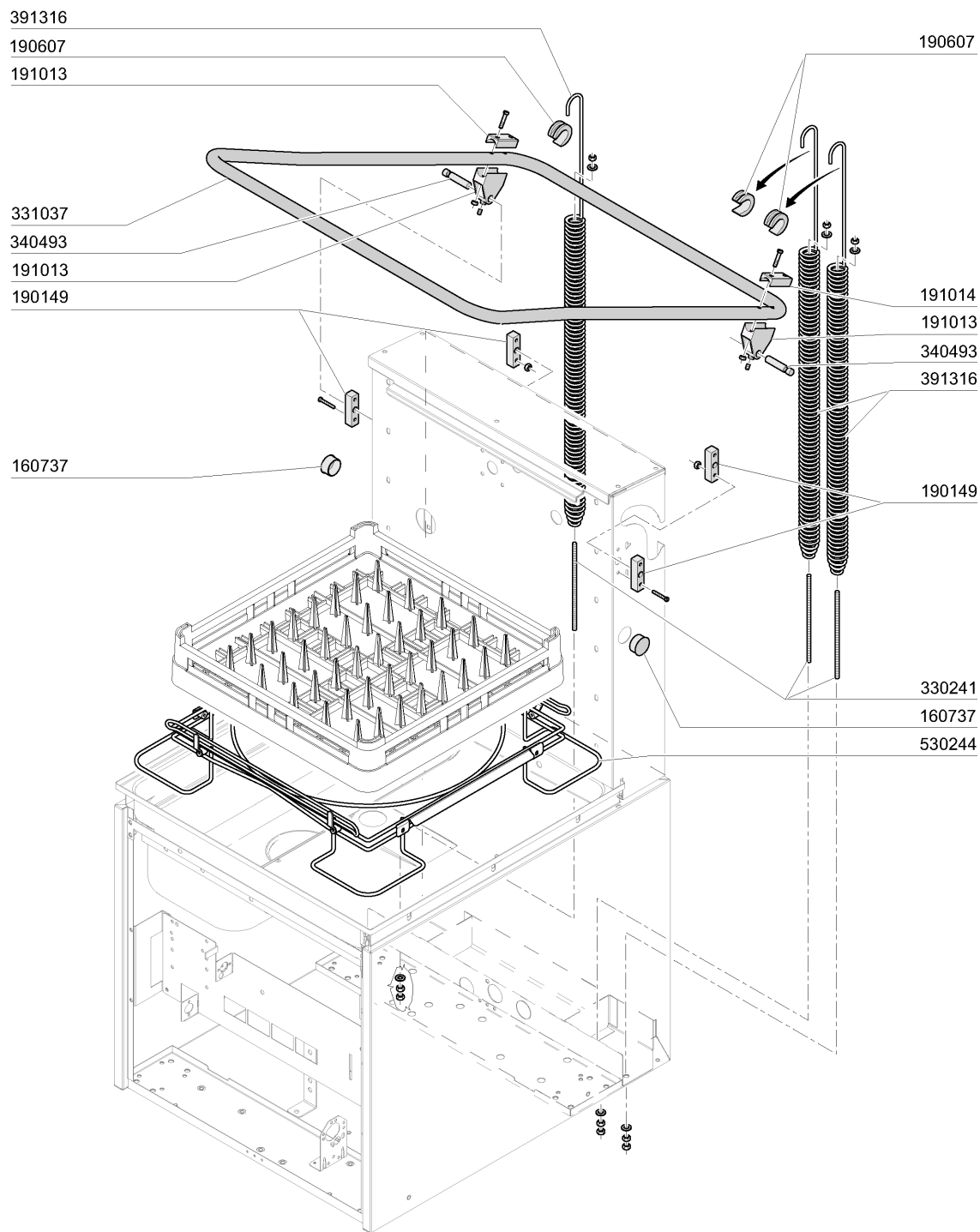

3 - Handle

CODE	DESCRIPTION
160737	PLUG HEYCO D.34,9
190149	REINFORCEMENT FOR HANDLE SUPP.
190607	HANDLE BUSH C30-70
191013	HINGE F. SUPPORT C30-C70
191014	FLANGE F. HANDLE C30-70
330241	SPRING ROD
331037	HANDLE C95-155-165 ISOLATED
340493	PIN F. HINGE C30
391316	SPRING FOR HANDLE C85/140-G75
530244	RACK SUPPORT

4 - Wash and rinse column

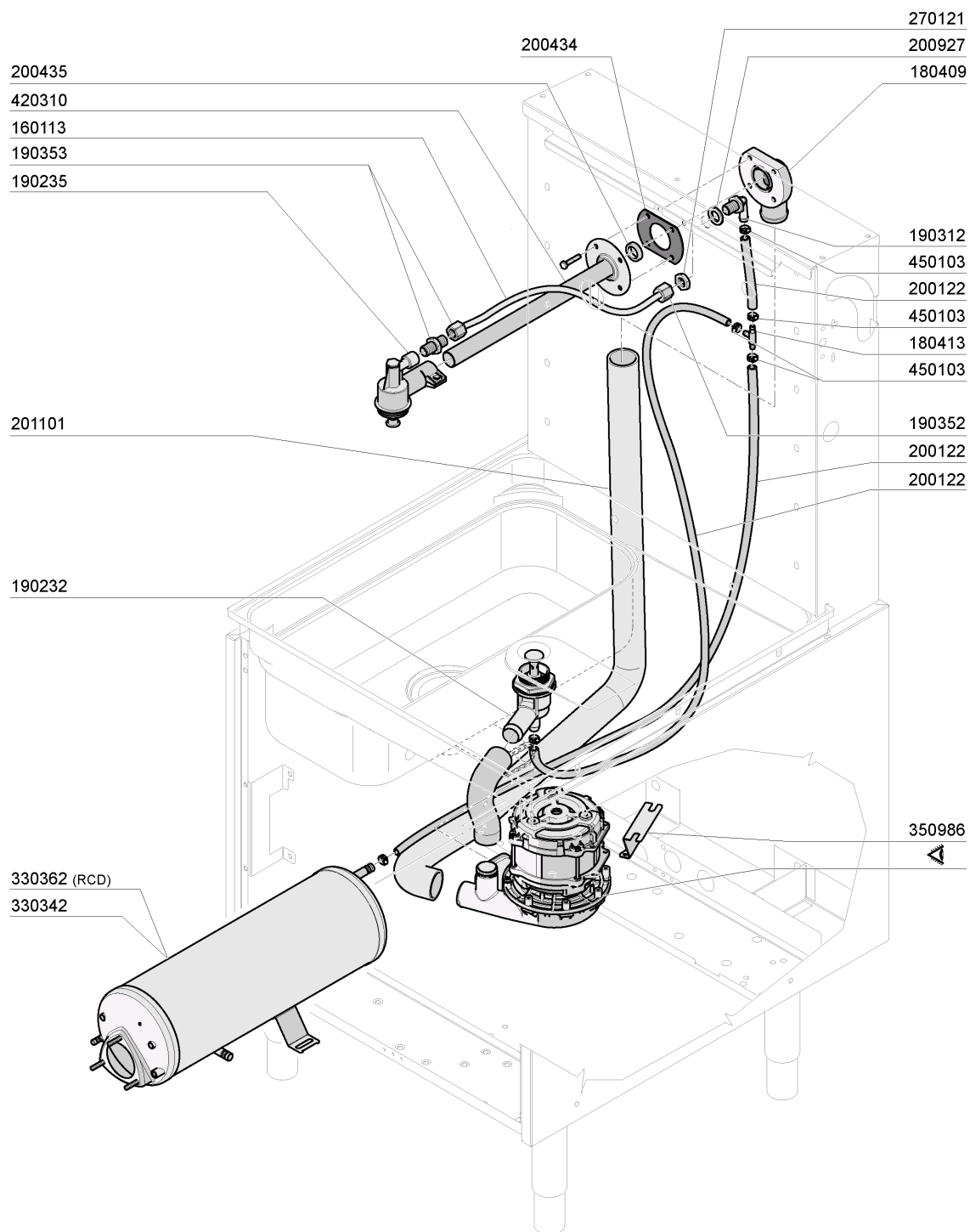

4 - Wash and rinse column

CODE	DESCRIPTION
160113	TUBE IN POL. RETIC. 12 EST
180409	UPPER CONNECTOR F. WASHING C30
180413	TEE NIPPLE D.11,5 - RINSE ASSE
190232	LOWER ARM SUPPORT FC2006
190235	UPPER ARM SUPPORT
190312	NIPPLE CONNECTION 1/2"
190352	CONNECTION
190353	CONNECTION
200122	HOSE 11X19
200434	GASKET CONNECTION C30 R50
200435	GASKET WASH.F2 D.40 C30-70
200927	GASKET FOR AIR TRAP
201101	OUTLET HOSE
270121	NUT FOR AIR TRAP
330342	BOILER C95-C155-C165
330362	BOOSTER FOR BREAK TANK
350986	PUMP SUPPORT
420310	LOW./UPP.WASH PIPE C30 - 70
450103	CLAMP FE ZN. 13-20 H=9

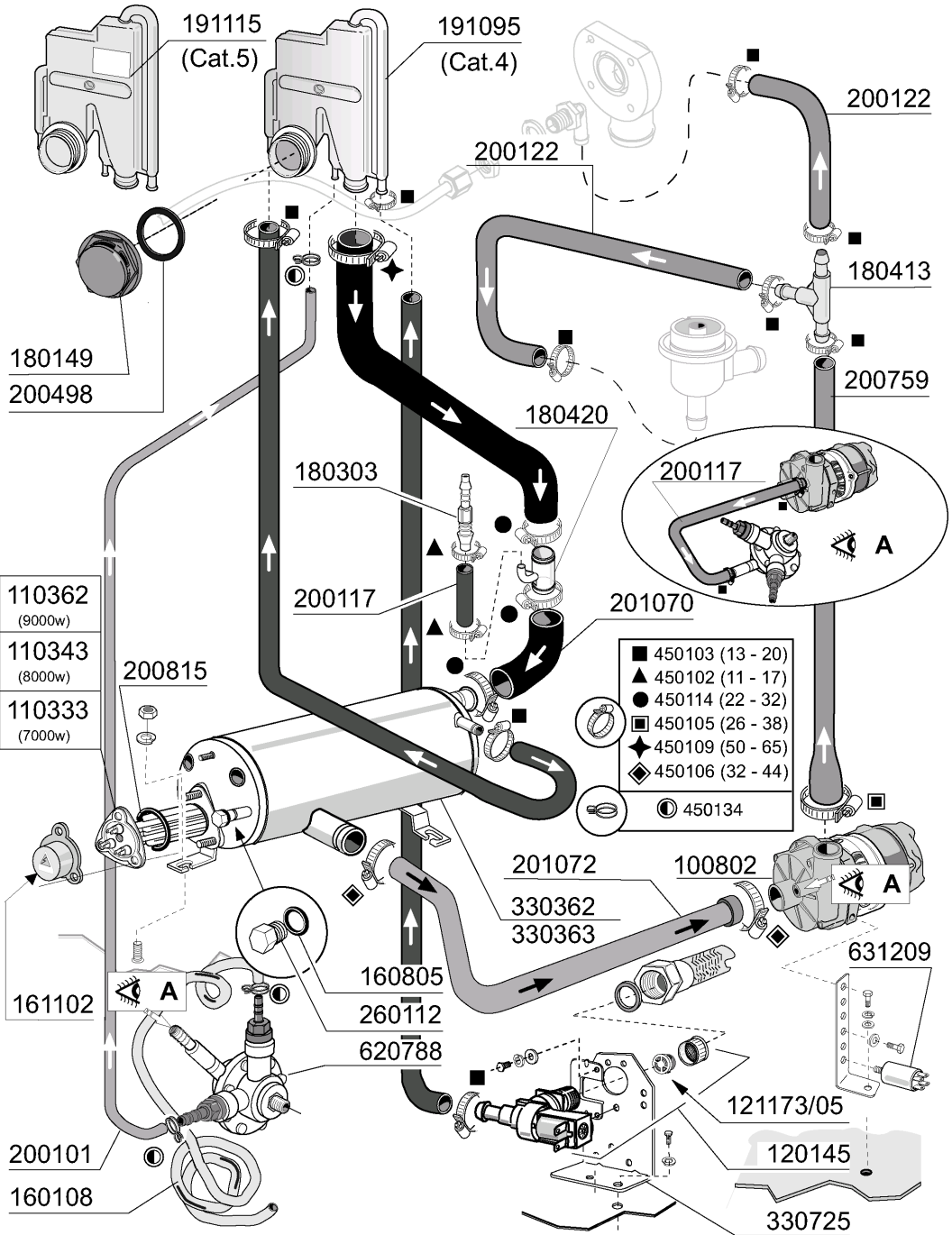

- 450103 (13 - 20)
- ▲ 450102 (11 - 17)
- 450114 (22 - 32)
- 450105 (26 - 38)
- ◆ 450109 (50 - 65)
- ◇ 450106 (32 - 44)
- 450134

5 - Rinse rcd

CODE	DESCRIPTION
100802	PUMP HP 0,3 230V-50HZ
110333	HEATER 7KW 230/400V
110343	HEAT.ELEM. 8000W 220/380V
110362	HEAT.ELEMENT 9000W 220/380V
120145	SOLENOID VALVE 12 LT 1 WAY
121173/05	REG.PORT.8 L/MIN ROSSO-09663
160108	INJECT.INLET HOSE D.8X5
160805	GASKET D.8
161102	ELEMENT COVER MOPL.
180149	PLASTIC NUT
180303	DOUBLE HOSE BARB
180413	TEE NIPPLE D.11,5 - RINSE ASSE
180420	TEE-NIPPLE
191095	CONTAINER FOR BREAK TANK
191115	BREAK TANK
200101	RUBBER TUBE 25X35
200117	RUBBER HOSE 7X16
200122	HOSE 11X19
200498	GASKET
200759	DELIVERY HOSE FOR ECORINSE AC-
200815	O-RING F. HEAT.ELEM.
201070	HOSE
201072	HOSE
260112	STAINLESS STEEL TE-SCREW 8X16
330362	BOOSTER FOR BREAK TANK
330363	BOILER FOR BREAK TANK
330725	STANDARD BRACKET F.SOLEN.VALV
450102	CLAMP FE ZN 11-17 H=9
450103	CLAMP FE ZN. 13-20 H=9
450105	CLAMP FE ZN. 26-38 H=12,2
450106	CLAMP FE ZN 32-44 H=12,2
450109	CLAMP 50-65
450114	CLAMP FE ZN.22-32 H=12,2
450134	ELASTIC HOSE CLIP D.9,3/8,8
620788	RINSE AID INJECTOR H21428
631209	ANTI-NOISE FILTER

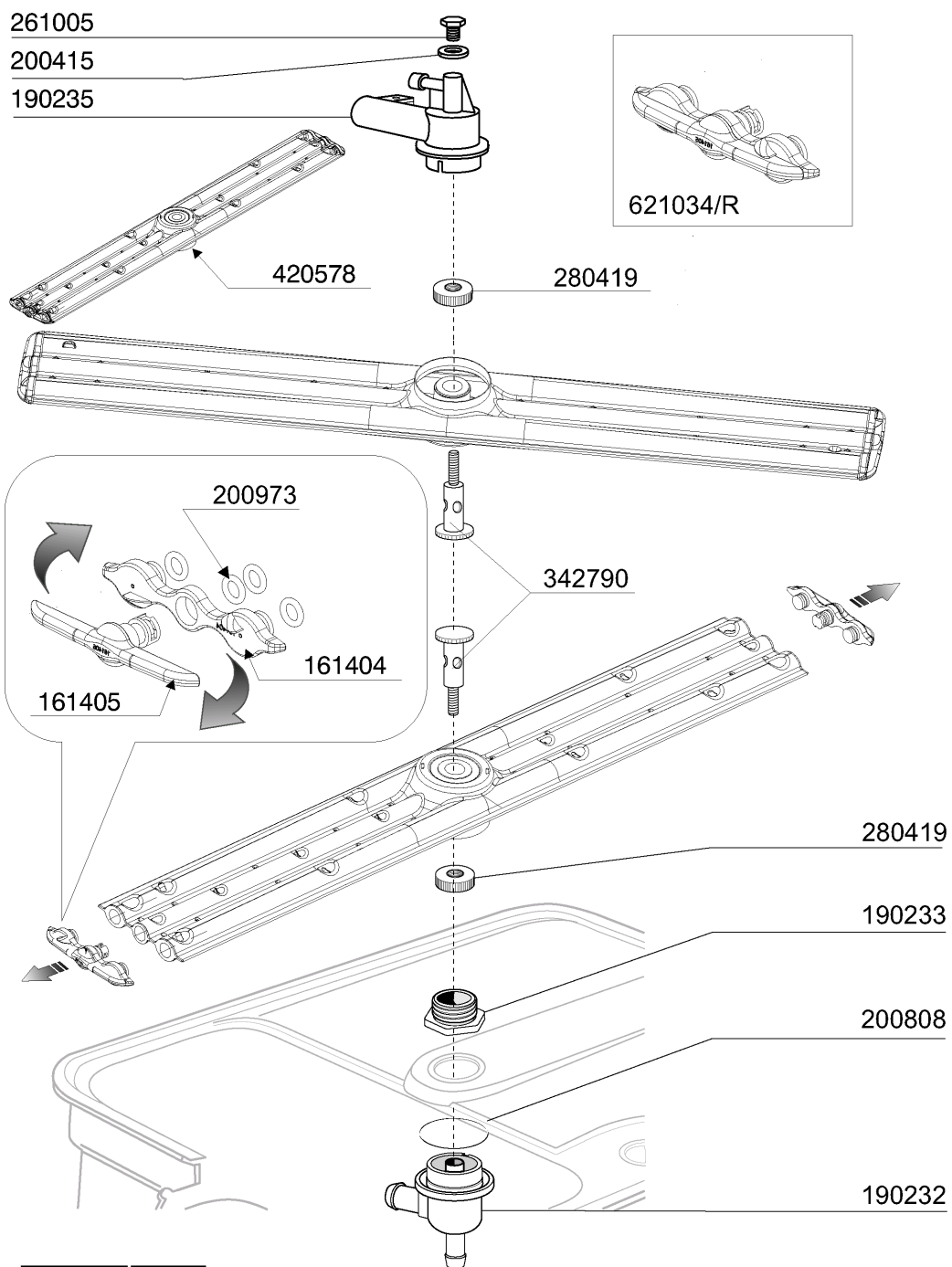

01-2011 | M. SA.

6 - Wash arm

CODE	DESCRIPTION
161404	PLUG
161405	PLUG
190232	LOWER ARM SUPPORT FC2006
190233	ARM SUPPORT
190235	UPPER ARM SUPPORT
200415	AIR TRAP GASKET -F2 18,5X10X3
200808	OR GASKET 3,53X50,80X57,86
200973	JOINT OR 1.78X5.28
261005	SCREW F. TEE UP.WASH F2-B41
280419	LOCK NUT
342790	RINSE SUPPORT
420578	WASH AND RINSE ARM FC2006
621034/R	ARM PLUG

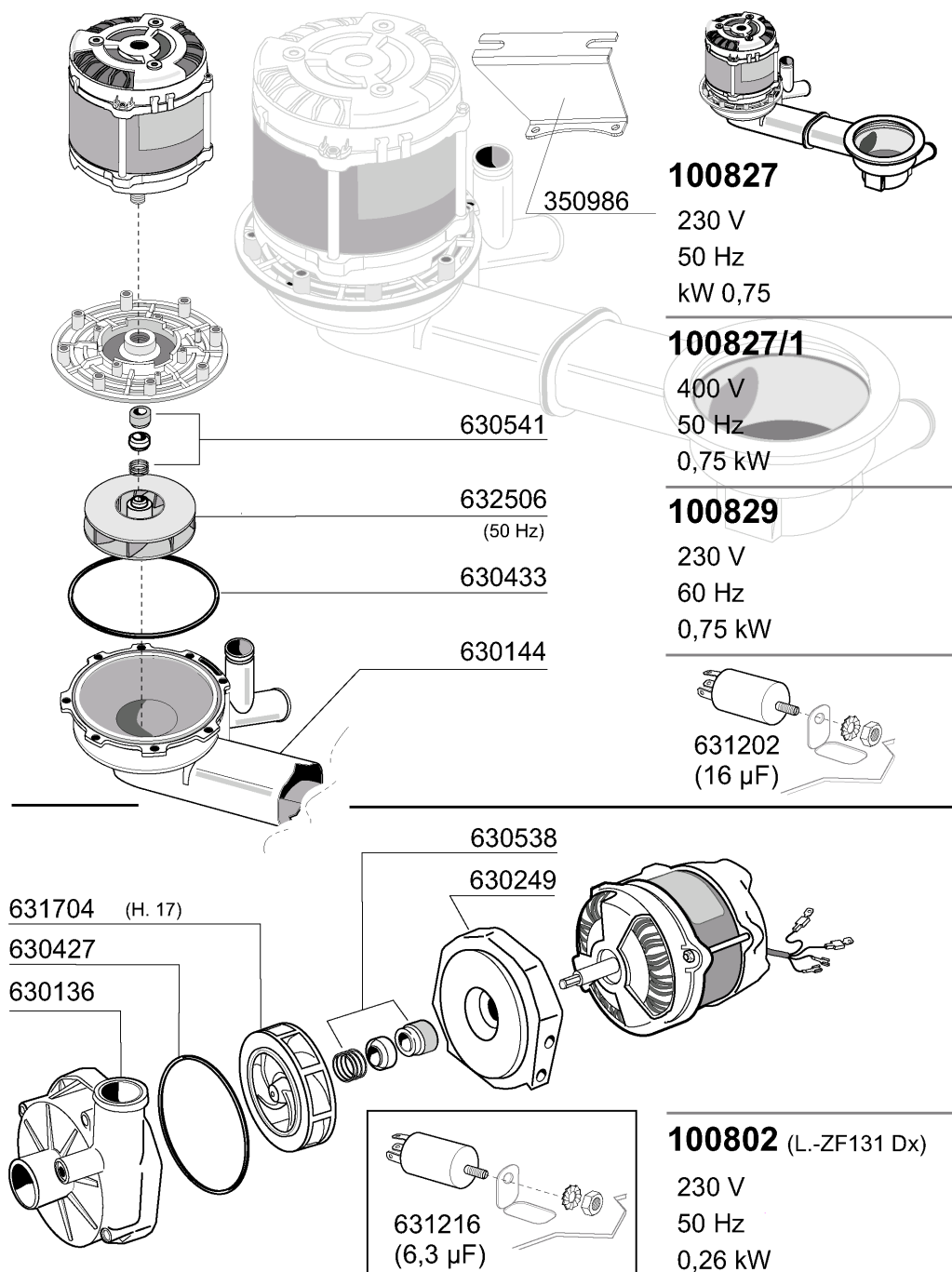

10 - 2010 | M. SA.

7 - Pump

CODE	DESCRIPTION
100802	PUMP HP 0,3 230V-50HZ
100827	WASH PUMP HP0,6 FC2006
100827/1	PUMP HP 0,6 LGB FC06 400/3/50
100829	PUMP HP 0,6 LGB FC06 60HZ
350986	PUMP SUPPORT
630136	PUMP VOLUTE LGB ZF131DX
630144	PUMP VOLUTE
630249	PUMP FLANGE ZF131 DX
630427	O-RING FOR PUMP ZF131DX
630433	GASKET FOR PUMP 100827
630538	SEAL LGBZF131DX
630541	SEAL FOR PUMP 100827
631202	CONDENSER 16 MF 450V
631216	CAPACITOR 6.3 MF 450V
631704	PUMP IMPELLER ZF131DX
632506	PUMP IMPELLER 100827 50HZ

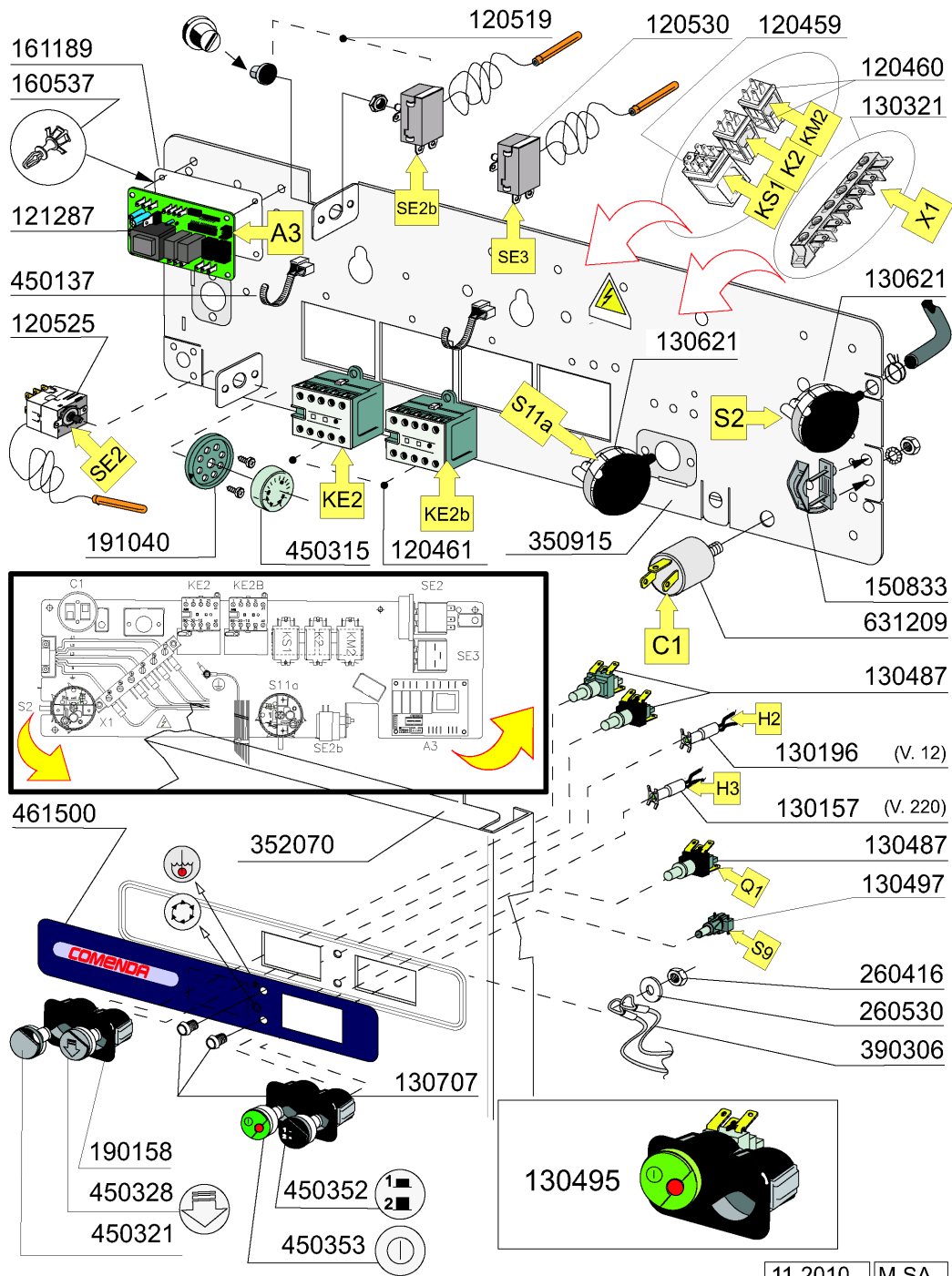

8 - Control box

CODE	DESCRIPTION
120459	AUXIL.RELE 16A 220V
120460	RELAY 16A 220V
120461	CONTACTOR ABB B6-30-01 220V
120519	SECURITY THERMOSTAT 95-125Ø
120525	BOOSTER THERMOSTAT 2 TEMPERAT.
120530	THERMOSTAT 0-90Ø
121287	ELECTRONIC TIMER
130157	GREEN LED FOR BR-BC-C-SERIES -
130196	GREEN LAMP
130321	JUNCTION BOX 6 CONNECTORS
130487	SWITCH
130495	SWITCH ON/OFF
130497	DISTANZIALE TAPPO PULSANTIERA
130621	PRESSURE SWITCH FOR BC HR 45/2
130707	TRANSPARENT LENS COVERS (C-SER
150833	CABLE HOLDER BC/BR
160537	ELECTRONIC CARD SPACER
161189	COVER
190158	SUPPORT
191040	FRAME F.THERMOSTAT KNOB
260416	STAINLESS STEEL NUTS M6
260530	STAINL.ST WASHER 7X22X2
350915	CONTROL PANEL SUPPORT
352070	FRONT PANEL
390306	CABLE
450137	COLLAR CONNECTION WITH BASE 31
450315	KNOB F. THERMOSTAT 90Ø
450321	GREY COVER FOR PUSH BUTTON BR-
450328	DRAIN SWITCH
450352	PUSH BUTTON "CYCLE"
450353	GREEN ON/OFF SWITCH
461500	PLATE LC411M
631209	ANTI-NOISE FILTER

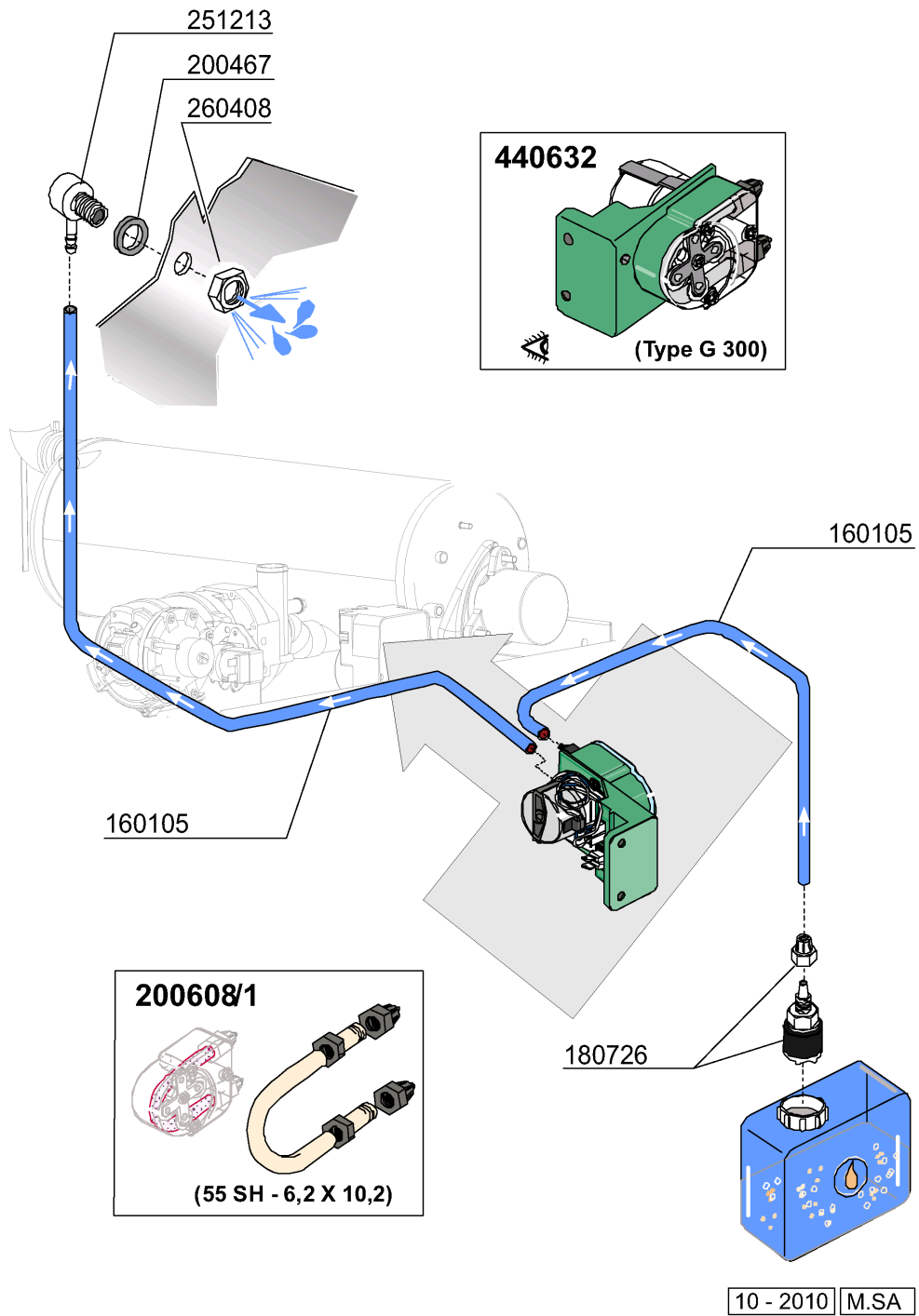

9 - Detergent dispenser

CODE	DESCRIPTION
160105	INJECT.INLET HOSE D.6X4
180726	STREINER FOR RINSE AID INJECTO
200467	DUTRAL GASKET F. AIR TRAP
200608/1	HOSE FOR DISPENSER GERMAC G300
251213	INJECTIOR S/S FOR DETERGENT IN
260408	S/S NUTS D.12
440632	DETERGENT INJECTOR

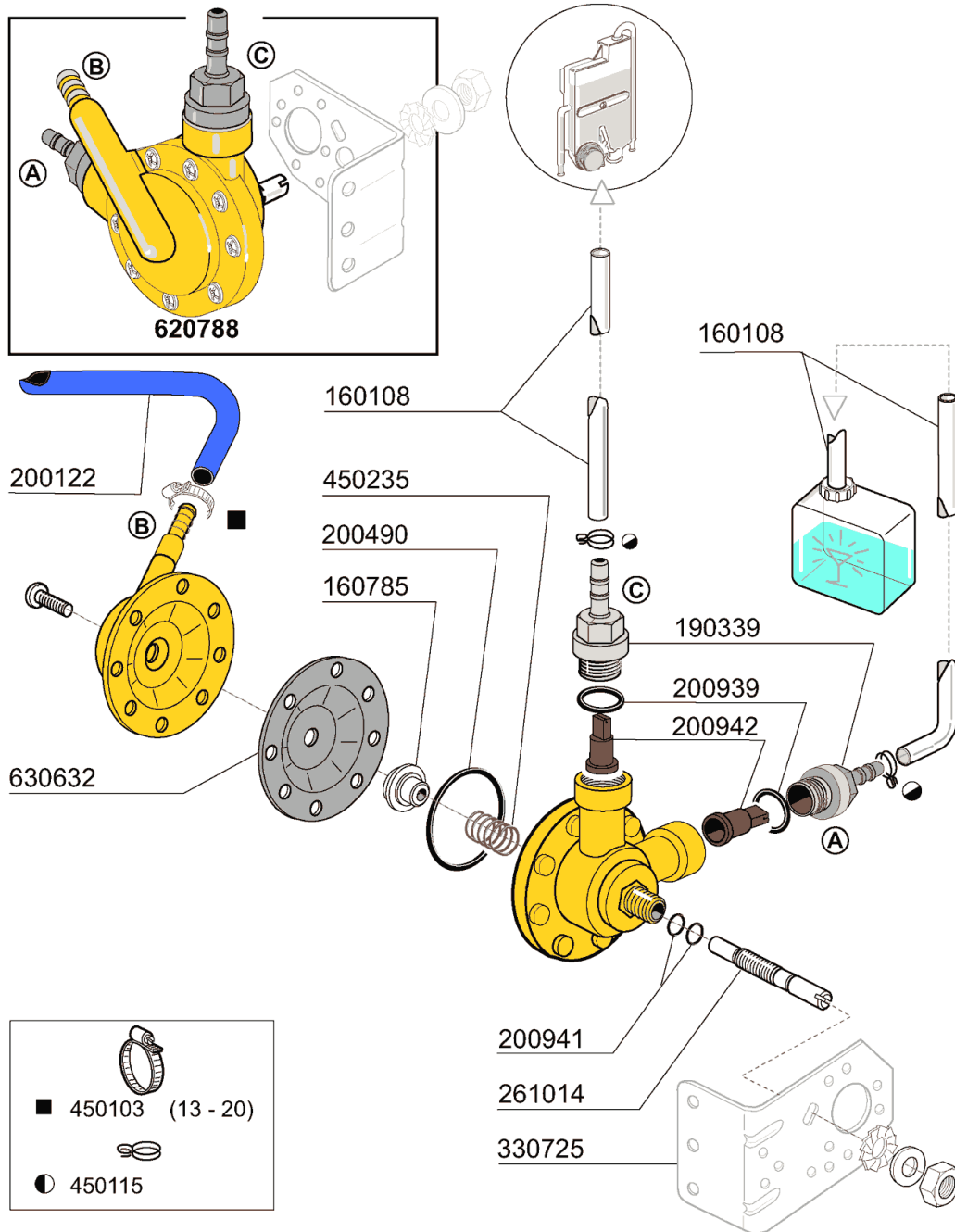

04 - 2007 | S. AG.

10 - Rinse aid injector

CODE	DESCRIPTION
160108	INJECT.INLET HOSE D.8X5
160785	GUIDE FOR SPRING RINSE AID INJ
190339	RINSE AID INJECTOR CONNECTION
200122	HOSE 11X19
200490	PROTECTION GASKET MOD.ADV.
200939	OR GASKET
200941	OR GASKET
200942	VALVE RINSE INJECTOR HVD
261014	SCREW
330725	STANDARD BRACKET F.SOLEN.VALV
450103	CLAMP FE ZN. 13-20 H=9
450115	ELASTIC CLAMP D.8,3/7,8
450235	SPRING RINSE AID INJECTOR
620788	RINSE AID INJECTOR H21428
630632	DIAPHRAGM RINSE INJECTOR HVD

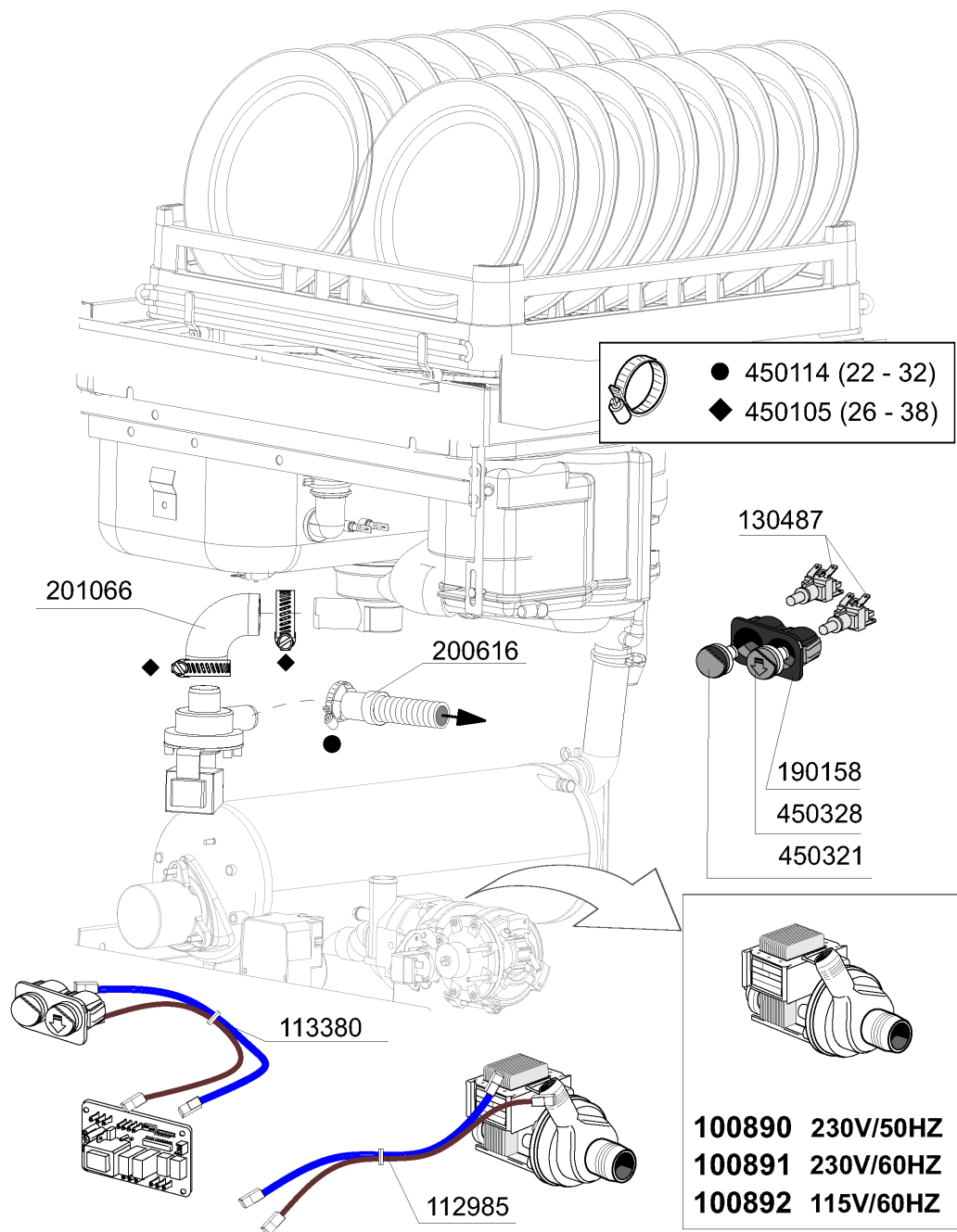

10 - 2010 | M.S.A.

11 - Drain pump kit

CODE	DESCRIPTION
100890	DRAIN PUMP 30W 220/50
100891	DRAIN PUMP 30W 220/60
100892	DRAIN PUMP 30W 115V/1/60HZ
112985	WIRING DRAIN PUMP LB
113380	CABLE
130487	SWITCH
190158	SUPPORT
200616	DRAIN HOSE 3MT FCM
201066	INLET HOSE LB DRAIN PUMP
450105	CLAMP FE ZN. 26-38 H=12,2
450114	CLAMP FE ZN.22-32 H=12,2
450321	GREY COVER FOR PUSH BUTTON BR-
450328	DRAIN SWITCH